

Belt Scale

FEATURES

- Robust single-idler belt scale for installation in belt conveyors
- Two single-point load cells with overload and transport protection
- Feed rates from 2 to 500 t/h
- Belt widths from 500 to 1,000 mm
- High frame stiffness
- Low installation height
- Easy installation
- Stainless steel version (optional)



DESCRIPTION

The belt scale ESW 2.3 serves to continuously record the quantity of bulk material during the transport on a belt conveyor. The ESW 2.3 is a robust and simple designed single-idler belt scale for stationary and mobile conveyors with belt widths up to 1,000 mm and feed rates up to 500 t/h. The belt scale can be used in nearly all kinds of conveyors.

The completely revised measurement mechanism of the ESW 2.3 with more robust load cells made of stainless steel results in a much higher stability in the transverse axis. Advantage for the service: The revised design of the belt scale also provides a quicker access to the load cells – this reduces time and effort.

The support bar and the weighing platform are made of powder-coated angle steel profile. The scale is optionally as a stainless steel or galvanized version available. The support bar serves as bracket for the weighing platform as well as for the speed measuring wheel. Two singlepoint load cells are installed on both sides of the weighing platform and are secured by a transport and overload protection.

The bulk material generates a pressure load on the measuring idler station which is recorded by the strain gauge load cells.

At the same time, the measuring wheel running simultaneously on the lower belt records the current belt speed. By the control unit, the signals of the load cells and the speed measurement are recorded, scaled and provided as a weight value in kg/h or t/h.

OUTLINE DIMENSIONS (MM)

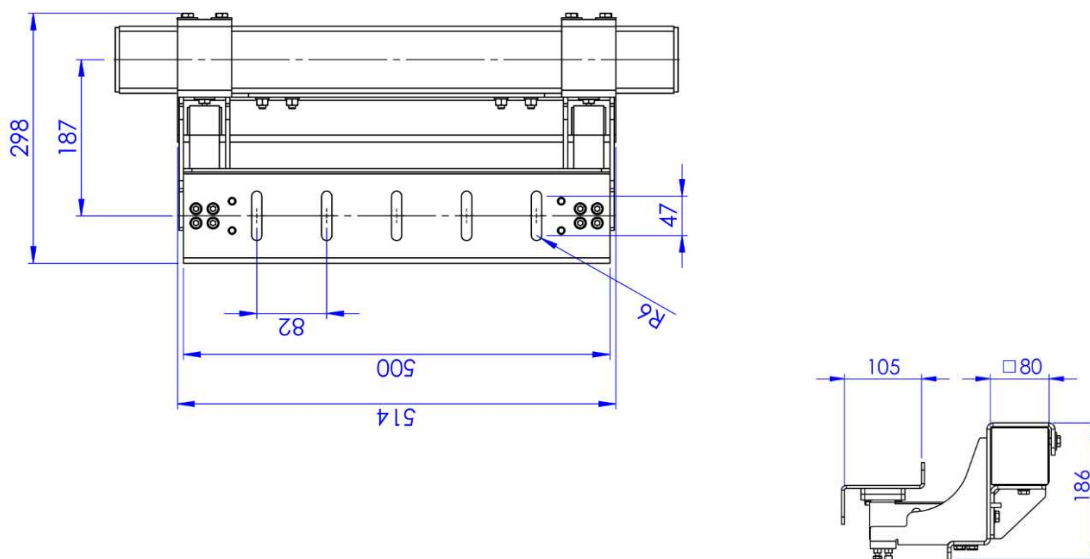

Belt Scale

Built-in belt scale ESW 2.3

consisting of support bar and weighing platform with two integrated strain gauge load cells

SPECIFICATIONS	
Feed rate	2 to 500 t/h
Belt width	500 to 1,000 mm
Combined measuring error of belt scale	± 1 % to max. 2 % in the range of 50 % and 100 % of the maximum feed rate and checked application in the temperature range from -10°C to +40°C
Material	angle or tube steel profile completely powder-coated, optionally painted or in stainless steel, fittings made of stainless steel
Weight scale	approx. 19 kg (without support bar)
Loadcell - full bridge single-point load cells (2 pcs.)	
Supply voltage	10 to 15 V DC - via control unit
Material	stainless steel, optionally nickel-plated steel
Electronic overload capacity	3 times nominal load, based on nominal feed rate
Electrical connection	6-wire cable
Working temperature range	-20°C to +70°C
Environmental protection	IP 69K (stainless steel), IP 66 (nickel-plated)
Measuring wheel MTS MR 10 - consisting of ball bearing mounted friction wheel with polyurethane running surface and inductive proximity switch	
Wheel diameter	200 mm, alternatively 160 mm
Wheel bar	stainless steel
Weight measuring wheel	approx. 5 kg
Proximity switch	
Supply voltage	10 to 36 V DC - via control unit
Outgoing signal	Voltage pulse, 22 per rotation
Switching function	PNP (NPN)
Electrical connection	M12-plug, 3-wire, cable length 5 m
Working temperature range	-25°C to +70°C
Environmental protection	IP 68

Alternatively, a rotary encoder can be used, which is mounted on the bend pulley.

Delivery includes: Weighing platform, support bars, measuring wheel or incremental encoder, junction box.

Idler stations can be delivered optionally.



Disclaimer

ALL PRODUCTS, PRODUCT SPECIFICATIONS AND DATA ARE SUBJECT TO CHANGE WITHOUT NOTICE.

Vishay Precision Group, Inc., its affiliates, agents, and employees, and all persons acting on its or their behalf (collectively, "VPG"), disclaim any and all liability for any errors, inaccuracies or incompleteness contained herein or in any other disclosure relating to any product.

The product specifications do not expand or otherwise modify VPG's terms and conditions of purchase, including but not limited to, the warranty expressed therein.

VPG makes no warranty, representation or guarantee other than as set forth in the terms and conditions of purchase. **To the maximum extent permitted by applicable law, VPG disclaims (i) any and all liability arising out of the application or use of any product, (ii) any and all liability, including without limitation special, consequential or incidental damages, and (iii) any and all implied warranties, including warranties of fitness for particular purpose, non-infringement and merchantability.**

Information provided in datasheets and/or specifications may vary from actual results in different applications and performance may vary over time. Statements regarding the suitability of products for certain types of applications are based on VPG's knowledge of typical requirements that are often placed on VPG products. It is the customer's responsibility to validate that a particular product with the properties described in the product specification is suitable for use in a particular application. You should ensure you have the current version of the relevant information by contacting VPG prior to performing installation or use of the product, such as on our website at vpgsensors.com.

No license, express, implied, or otherwise, to any intellectual property rights is granted by this document, or by any conduct of VPG.

The products shown herein are not designed for use in life-saving or life-sustaining applications unless otherwise expressly indicated. Customers using or selling VPG products not expressly indicated for use in such applications do so entirely at their own risk and agree to fully indemnify VPG for any damages arising or resulting from such use or sale. Please contact authorized VPG personnel to obtain written terms and conditions regarding products designed for such applications.

Product names and markings noted herein may be trademarks of their respective owners.

Copyright Vishay Precision Group, Inc., 2014. All rights reserved.