

## Weigh Module

### FEATURES

- Capacity range: 1, 2, 5, 10, 20, 30, and 50 kN (450, 1.12K, 2.25K, 4.5K, 6.75K, and 11.2 K lb)
- Easy installation
- Moveable load point
- Withstands very high lateral forces
- Extremely accurate and rugged
- ATEX, IECEx, FM, CSA certified for hazardous locations

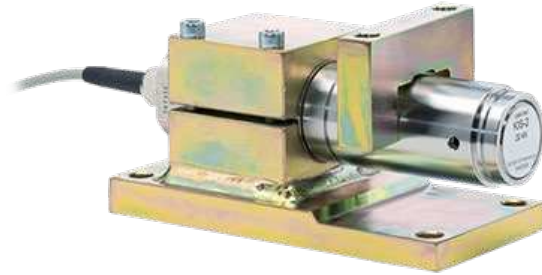

### APPLICATIONS

- Batch/blend/mix systems
- Reactor vessels
- Quality-critical process weighing
- Precision force measurement
- Conveyor belts
- Web tension



### DESCRIPTION

KIS-2 load cells have several features that clearly distinguish them from other load cells. They are easy to install and extremely accurate, even when subjected to dynamic process forces and severe environmental conditions. All KIS load cells can be ATEX, IECEx, FM, CSA certified for use in explosive atmospheres.

### OUTLINE DIMENSIONS

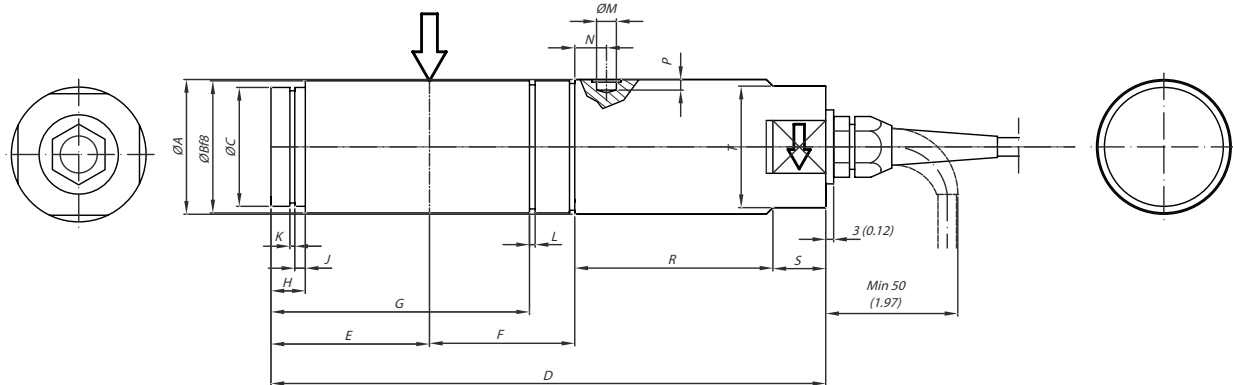

RANGE kN (lb)	ØA	ØB	ØC	D	E	F	G	H	J	K	L	ØM	N	P	R	S	T
1-2-5	34 (1.34)	33 (1.30)	29 (1.14)	166 (6.54)	46 (1.81)	35 (1.38)	-	10 (0.39)	2.5 (0.10)	1.6 (0.06)	-	4.4 (0.17)	10 (0.39)	3 (0.12)	70 (2.75)	15 (0.59)	30 (1.18)
10-20-30	51 (2.00)	50 (1.97)	45 (1.77)	210 (8.27)	60 (2.36)	55 (2.16)	97.85 (3.85)	13 (0.51)	4 (0.16)	1.85 (0.07)	2.15 (0.08)	7.5 (0.29)	12 (0.47)	4 (0.16)	75 (2.95)	20 (0.79)	46 (1.81)
50	77 (3.03)	75 (2.95)	70 (2.76)	288 (11.34)	95 (3.74)	65 (2.56)	141.3 (5.56)	12 (0.47)	5 (0.20)	2.65 (0.10)	2.65 (0.10)	9.1 (0.36)	12 (0.47)	8.5 (0.33)	108 (4.25)	20 (0.79)	60 (2.36)

Dimension shown in mm (in)

Weigh Module

**OUTLINE DIMENSIONS** cont.

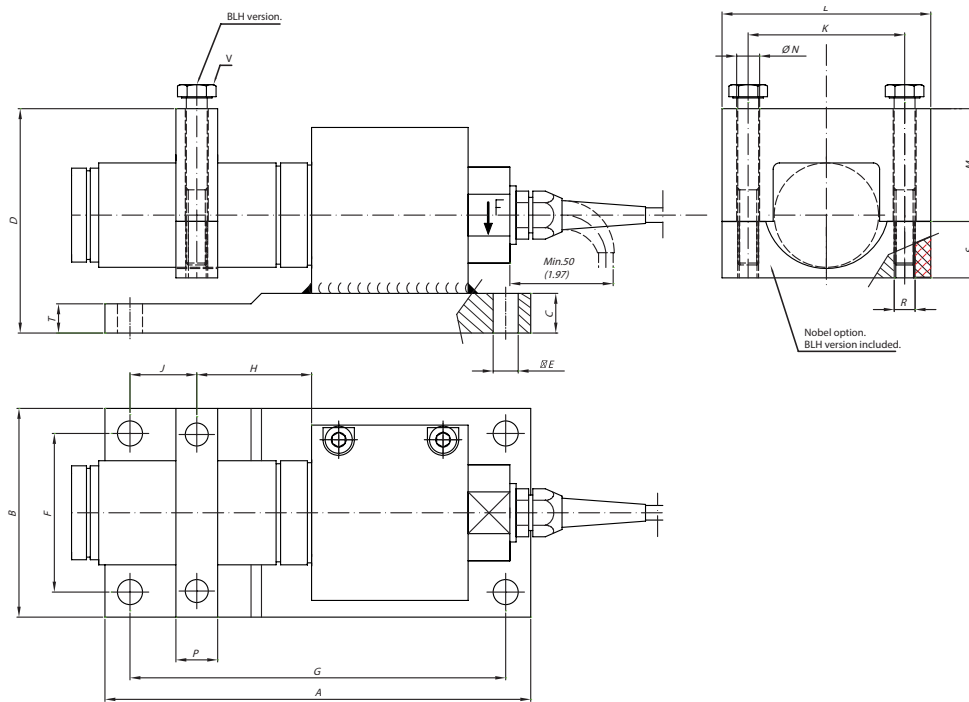

RANGE KN	A	B	C	D	ØE	F	G	H	J	K	L	M	ØN	P	T	R	S
1-2-5	175 (6.89)	75 (2.95)	14 (0.55)	81 (3.19)	12 (0.47)	51 (2.01)	151 (5.94)	35 (1.38)	31 (1.22)	55 (2.17)	70 (2.76)	41 (1.61)	8.5 (0.33)	19 (0.75)	14 (0.55)	M8	19 (0.75)
10-20-30	204 (8.03)	100 (3.93)	19 (0.75)	107.5 (4.23)	12 (0.47)	76 (2.99)	180 (7.08)	55 (2.16)	32 (1.26)	75 (2.95)	100 (3.93)	54 (2.12)	11 (0.43)	19 (0.75)	14 (0.55)	M10	27 (1.06)
50	280 (11.02)	150 (5.90)	30 (1.18)	152 (5.98)	16 (0.63)	115 (4.53)	245 (9.64)	65 (2.56)	45.5 (1.79)	115 (4.53)	150 (5.90)	72 (2.83)	18 (0.71)	29 (1.14)	30 (1.18)	M16	43 (1.69)

RANGE KN	V
1-2-5	M8-1.25X70 (2.755) LG
10-20-30	M10-1.5X90 (3.543) LG
50	M16-2X120(4.724) LG

Dimension shown in mm (in)

## Weigh Module

<b>SPECIFICATIONS</b>	
PARAMETER	
<b>PERFORMANCE</b>	
Rated load (RL)	1, 2, 5, 10, 20, 30, 50 kN
Combined error (terminal)	±0.05% RO
Repeatability	0.01% RO
Overload,* safe	200% RL, 150% RL for 30 kN and 50 kN
Overload,* ultimate	300% RL, 200% RL for 30 kN and 50 kN**
Uplift, safe	100% RL
Uplift, ultimate	120% RL
Side load,* safe	100% RL, 50% RL for 30 kN
Side load,* ultimate	200% RL, 100% RL for 30 kN
Input voltage, recommended	10 VDC or VAC
Input voltage, maximum	18 VDC or VAC
Input resistance	350 Ω ±3 Ω
Output resistance	350 Ω ±3 Ω
Rated output (RO)	2.040 mV/V
Tolerance of RO	±0.25% RO
Zero balance	±5% RO
Tolerance of shunt calibration values	±0.25% of value
Creep at RL after 30 minutes	±0.03% RL
Temperature range (wider temperature range available upon request)	-40 to +105°C -40 to +212°F
Temperature effect, on output (-10°C to +50°C)	±0.0033% of output/°C ±0.00018% of output/°F
Temperature effect, on zero balance (-10°C to +50°C)	±0.0014% of RO/°C ±0.0008% of RO/°F
Insulation resistance at 200 VDC	>4 GΩ
Material: Load cell	Stainless steel
Material bracket, yoke and tilt guard	Yellow chromate steel, stainless steel as an option
Electrical connection	10 m shielded four conductor cable (BLH version)
	5 m shielded four conductor cable (Nobel version)
Degree of protection	IP67
<b>APPROVALS</b>	
ATEX, IECEx, FM, CSA certified versions are available upon request. For details contact <a href="mailto:blhnobel@vpgsensors.com">blhnobel@vpgsensors.com</a> .	

\* Referring to recommended loading point.

\*\* 50 kN BLH version only.

BLH Nobel is continually seeking to improve product quality and performance. Specifications may change accordingly.

## Disclaimer

ALL PRODUCTS, PRODUCT SPECIFICATIONS AND DATA ARE SUBJECT TO CHANGE WITHOUT NOTICE.

Vishay Precision Group, Inc., its affiliates, agents, and employees, and all persons acting on its or their behalf (collectively, "VPG"), disclaim any and all liability for any errors, inaccuracies or incompleteness contained herein or in any other disclosure relating to any product.

The product specifications do not expand or otherwise modify VPG's terms and conditions of purchase, including but not limited to, the warranty expressed therein.

VPG makes no warranty, representation or guarantee other than as set forth in the terms and conditions of purchase. **To the maximum extent permitted by applicable law, VPG disclaims (i) any and all liability arising out of the application or use of any product, (ii) any and all liability, including without limitation special, consequential or incidental damages, and (iii) any and all implied warranties, including warranties of fitness for particular purpose, non-infringement and merchantability.**

Information provided in datasheets and/or specifications may vary from actual results in different applications and performance may vary over time. Statements regarding the suitability of products for certain types of applications are based on VPG's knowledge of typical requirements that are often placed on VPG products. It is the customer's responsibility to validate that a particular product with the properties described in the product specification is suitable for use in a particular application. You should ensure you have the current version of the relevant information by contacting VPG prior to performing installation or use of the product, such as on our website at [vpgsensors.com](http://vpgsensors.com).

No license, express, implied, or otherwise, to any intellectual property rights is granted by this document, or by any conduct of VPG.

The products shown herein are not designed for use in life-saving or life-sustaining applications unless otherwise expressly indicated. Customers using or selling VPG products not expressly indicated for use in such applications do so entirely at their own risk and agree to fully indemnify VPG for any damages arising or resulting from such use or sale. Please contact authorized VPG personnel to obtain written terms and conditions regarding products designed for such applications.

Product names and markings noted herein may be trademarks of their respective owners.

Copyright Vishay Precision Group, Inc., 2014. All rights reserved.